

HOM AUTOMATION PVT LTD  
Better Security Better Manpower Utilization

# **INSTALLATION / OPERATION MANUAL**

## **HOM AUTOMATIC AXLE ROAD BLOCK**

### **SYSTEM**

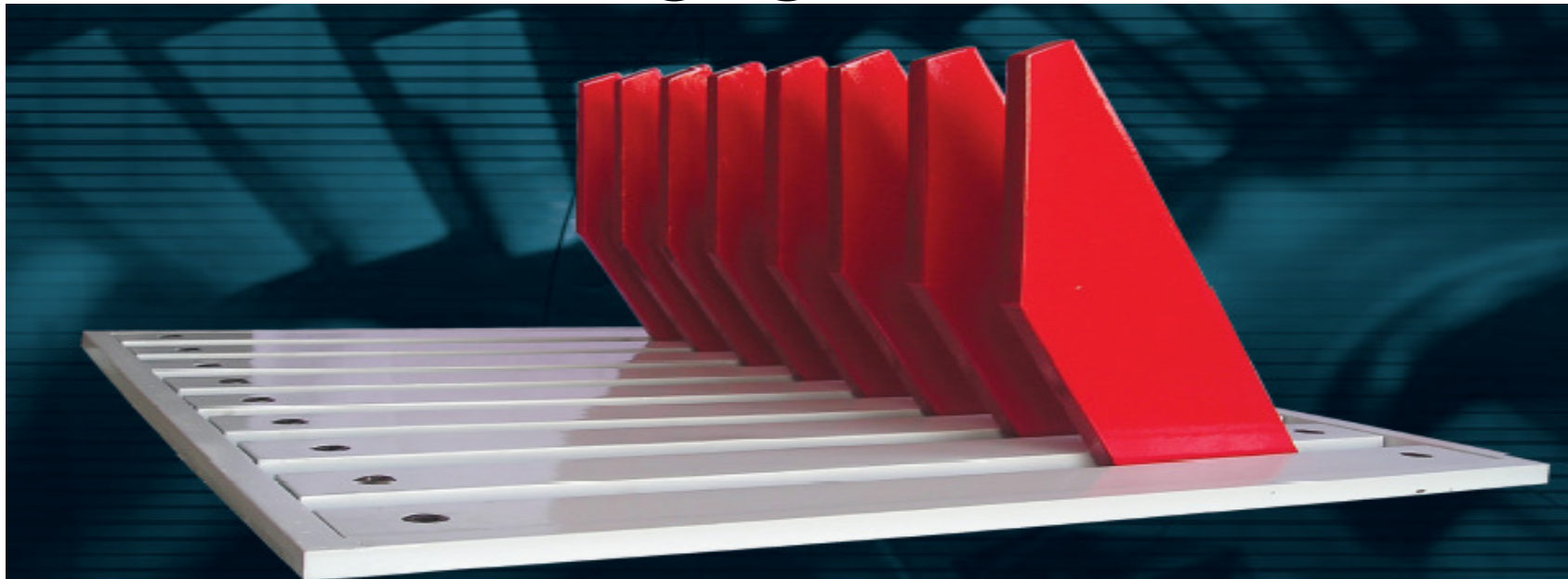

## **CONTENTS**

1. Introduction.
2. Function.
3. Construction.
4. Technical Data
5. Pre-installation Checks.
6. Tools Required
7. Parts of Axle Road Block
8. Mechanical Parts
9. Electrical Parts
10. Electronics Parts
11. Activating Devices
12. System Installation
13. Power System
14. Do verify before operation
15. PCB Layout
16. Safety Instruction
17. General Maintenance & Trouble Shooting Guide
18. Technical Support
19. TOP, FRONT & SIDE ELEVATION VIEW

## **INTRODUCTION:**

HOM Automatic Axle Road Blocks with electro-hydraulic drive unit – consisting of underground casing with drainage and spikes. With drive unit and control panel in a separate cabinet for outdoor installation. HOM Automatic Axle Road Blocks are designed to restrict and stop forceful entries of vehicles at defense installations, Oil refineries, Atomic Power Plants, Shopping Malls & other security sensitive sites. HOM Automation offers compact Solid Spike Road Blocks to stop or prevent unauthorized vehicle or forceful entry.

## **FUNCTION:**

While the blocking spikes of Axle Road Block are in lowered position the driveway is free for passage of vehicles. The blocking spikes can be raised via “Push Button” or “Remote Control” and will be locked in this position thus the drive away is blocked. The same push button can be used to unlock the spikes which will lower the spikes and thus making driveway free again for passage.

## **CONSTRUCTION:**

The underground casing consists of an all around closed sheet steel casing with concrete anchors. Within the casing are the bearing for the hydraulic cylinder with control valves.

The top of casing is equipped with a cover which allows passage of even the heaviest vehicle of 25 tones. The solid blocking spikes are welded to the solid rotational axis in a distance of approx. 125mm to each other. The Axis is connected with the hydraulic cylinder via lever system.

**COLOR:** Spikes : Red  
Cover Plate: Yellow.

### **TECHNICAL DATA SHEET OF AXLE ROAD BLOCK**

Size	3000( L) X 1000 (W) X 560 (H) mm
Blocking Width	3000mm
Installation Width of Casing	3200(L) X 1100 (W) x 580 (H)
spikes above ground	500 (H) X 150(W) X 25 (T) mm
Distance between Spikes	125mm
Spike Rotor	Pipe dia 140mm, 20mm thickness
Steel Plate in between Spikes	100 (W) X 950 (L) X 25(T) mm
Mechanism Box Size	1270(H) X 610 (W) X 610 (W)
Opening/closing time	4-6sec
Blocking height of spike above road level	500mm
Fully Raised blocking position of spikes	60 degree
Mechanism	Hydraulic
Cylinder	Double
Motor	AC Crompton, Single Phase, 3 HP, 1400 rpm
Electronic Mechanism	IC Controlled
Input Voltage	230V AC 50 Hz
Input Signals for operation (Optional)	Push Button Card Reader Finger Scanner Remote Controller Sensor etc
Locking Mechanism	Electro-magnetic Lock
Accessories	Pressure Valve Limit Switches Hydraulic Oil Oil Tank & Pipe fittings

## **PRE- INSTALLATION CHECK:**

- At the site of installation observe the frequency and type of traffic. Axle Road Blocks (ARB) are designed to stop the vehicular traffic only. Pedestrian must be strongly advised not use the passage.
- Check to see if Automatic barrier is to be integrated with Axle Road Block. If yes, discuss the distance between barrier and Axle Road Block. Ideally there should be 10 to 15 ft distance between the two. Be sure space is available for barrier to operate. Also understand how client would want to operate the two systems.
- As the Axle Road Block unit is very heavy (around 2000-3000 kg). Ensure that client is aware of the need of a crane to off-load the unit from the truck.
- ARB require digging a trench across the road that will disrupt the traffic. Ensure that client is fully aware of this and an alternate route for the regular traffic has been chalked out.
- Some clients may like to have a provision to drain out rain water. Please ensure that client is aware that drainage system is not in the scope of installation. However the same can be provided at an extra cost.
- Ensure that 220 V AC (single phase) is available inside guard-room or as close to the installation point as possible.

## **Tools Required:**

- A set of Spanners, screwdrivers and Philip head screwdrivers.
- Wires, conduits, wire cutter, stripper, and file, measuring tape, cable ties, electrical tape and multimeter.
- Road cutting tools and hammers.
- Electrical drill machine.
- Welding machine.

## **PARTS OF AXLE ROAD BLOCK.**

Each HOM Automatic Axle Road Block System consists of the following parts:

- One Mechanism consisting AC motor.
- One Axle Road Block unit of required length.
- One control panel box consisting of microprocessor based PCB's and transformer.
- One remote control unit (one transmitter and one receiver).
- One piano type push button
- 8 meter of conduit and wires. Running more than 8m of cable will be charged extra.

HOM Automatic ARB are modular in design, with all the mechanical, electrical and electronics components mounted on an easily removable sub chassis.

Mechanical Parts:

1 **Mechanism Box:** The body of barrier box is made up of GI sheet of thickness 16 gauge. The dimension of the box is: 1210 X 610 X 610 mm. It houses electrical AC motor, pump, oil tank and control panel box. The body is placed on a concrete platform with a specially designed MS angle platform bolted to the body.

2 **Drive Unit:** Electro-mechanical drive unit is operated by microprocessor based control panel. The system consists of Hydraulic pump, Oil tank and Single phase 3 HP motor etc.

3 **Control Panel Box:** Control panel box contains the control card and transformers. It is made of M.S. sheet of 2mm.thickness. Slots are provided for air-cooling and to release the heat generated by the electronic components.

4 **Paint:** The Mechanism Box is painted with 20 micron thick spray. The spike is in Red Colour. While the cover plate is painted in yellow.

### Electrical Parts

1 **Motor:** Ac motor, single phase, 3HP, 1400rpm. Heavy duty, and maintenance free motor is used for long lasting trouble free operation. Maintenance requires cleaning carbon brushes once in two year or more often depending upon frequency of operation.

2 **Push Button:** A piano type push button is provided inside the guardroom. Touching the push button for a second activates the barrier. Thus keeping the guard free to pay more attention to security checks.

3 **Transformers:** Transformers having output specifications power the system.

Low Voltage Supply Transformer

Input supply Voltage	220 V
Output Voltage	0-12 V
Current Rating	500 mA.

Optional Activating Devices:

- Microprocessor based control panel is designed to integrate easily with other activating devices such as biometrics or proximity card reader, optical beam sensor, loop detector etc.

## **INSTALLATION INSTRUCTIONS:**

Caution: It is strongly recommended that installation be carried out by experienced and skilled technician to avoid injury and or accidental damage!

### **Unpacking Cartons:**

HOM Automatic Axle Road Block is dispatched in several cartons. Please check with challan / bill to ensure that all parts have been delivered. These parts are wrapped in a bubble-wrap, padded with thermocol sheets and packed with double walled cardboard carton or wooden case. The cases are secured with metal straps all around.

### **SYSTEM INSTALLATION :**

- Installing axle road block requires digging a trench of 1100mm wide, 580mm deep and 3200 long across the road.
- The water drain is connected to a nearby underground tank through a 3" dia PVC pipe or Water can be drained out of the tank using a ordinary submersible pump.
- Setting Foundation: Foundation is a strong rectangular shape, M.S. angle iron structure , supplied along with Axle Road Block. It is to be placed in a pit. The foundation frame is to be set in concrete, keeping one inch above the ground. Bolts on frame should project upward. Allow sufficient time for concrete to set. The outline of the foundation structure is same as the Mechanism box and may therefore be used as a guide for location.
- Fitting Mechanism box on foundation: Once the foundation is set the Mechanism box may be lifted over the four projecting bolts from foundation and fitted and tightened using the washers and nuts.
- Electro-mechanical Assembly : The Axle Road Block is supplied with Hydraulic pump, electrical motor, Oil tank and control panel partly assembled in factory.

- **WARNING:** Moving parts inside the mechanism Box may cause severe injury.
- **Laying Cables:** Once the Mechanism box is firmly placed and Axle Road Block is fitted, Cable is laid out underground from Mechanism box to guard room.
- **Control panel:** HOM Automatic Axle Road Block system has many features and options. Most are controlled by electronic circuit board inside the control box. LED operator lights on the circuit board provide information to maintain and trouble shoots the operation.
- The circuit board is factory set and should not be altered in any way or the warranty may become void. If an adjustment is to be made please call HOM Automation Pvt. Ltd.

PS: Please do not open either drive mechanism box or carry out any modification in electronic control panel. This will invalidate your warrantee.

## Power System

- Specification of motor

Type	: AC Induction Motor
Power	: 3 H.P.
Phase	: Single
RPM	: 1400
Voltage	: 220-230V
Weight	: 17 Kg.

- Specification of the transformer

Input Voltage	: 220VAC
Output Voltage	: 12VAC
Rated Output Current	: 500mA

## **DO VERIFY BEFORE OPERATION:**

Before first time operation, please check the followings

- 1 Input power supply is 190V to 240V.
- 2 Output voltage of both the transformers should be 24-12-0-12-24 V AC & 0-12V AC
- 3 Power LED should be glowing.
- 4 All the connections are tight.
- 5 Error LED should be off.
- 6 DIP switch are set properly.
- 7 All the sensors / remote etc are connected to their respective connector.
- 8 Ground of all the devices is mixed with the ground of control card.
- 9 Optical Beam sensor alignment. Transmitter and receiver should have light beam in line.
- 10 Drive unit pump coupled properly with motor. It should be easy to rotate with hand smoothly.
- 11 Control panel is secured in a water safe place.
- 12 Connections of motor are properly done.

# PCB LAYOUT:

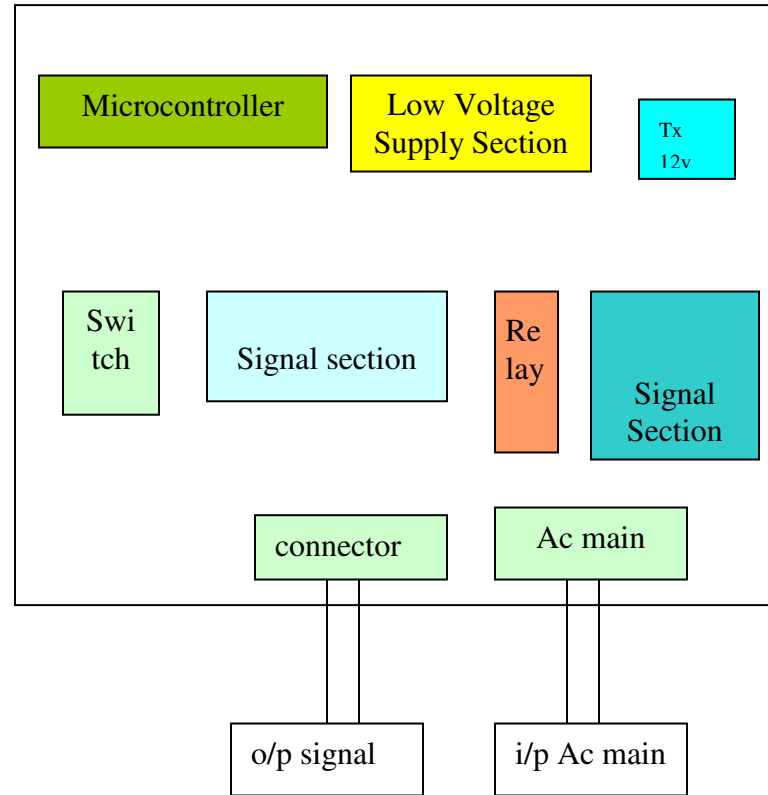
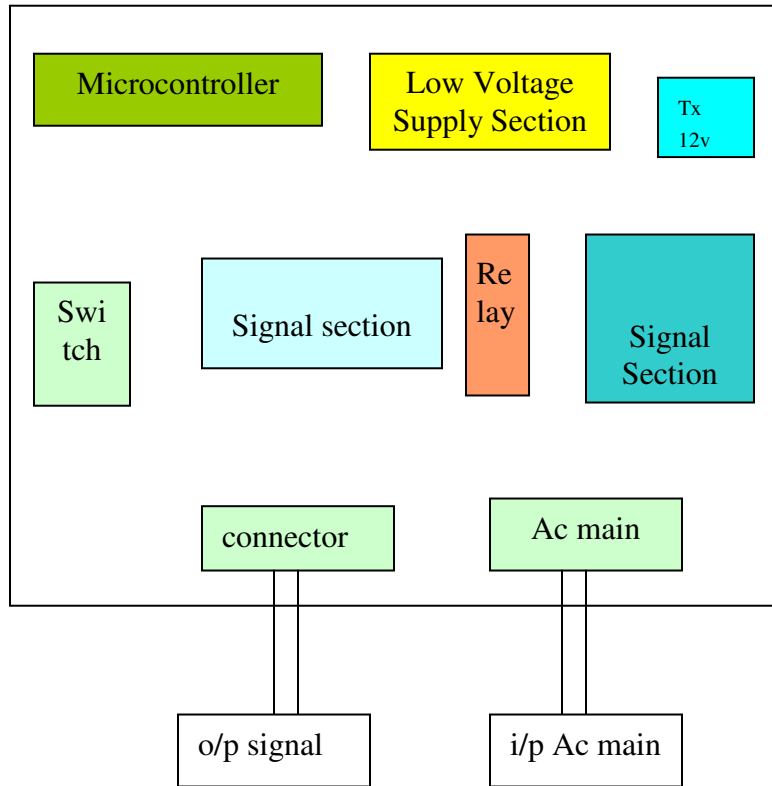

## **SAFETY INSTRUCTION TO END-USER:**

- HOM Automatic Axle Road Block System is designed to control the access of vehicular traffic and as such is not recommended for pedestrian traffic.
- Locate push button and Remote at a safe distance from the Axle Road Block and out of reach of children and unauthorized persons.
- Push button and Axle Road Block should be in line of sight of operator. Operator should be highly alert and keep an eye on the road while operating Axle Road Block. Carelessness in operating the block may cause damage to vehicles.
- Always turn off power before servicing either electrical or mechanical parts. Stay away from moving parts at all time. Keep clear of all possible pinch points.

Caution needs to be exercised in operating Axle Road Block to avoid any inadvertent injury to a person or damage to vehicle. The operator must always be in sight of Axle Road Block and must ensure that the vehicle and or person are not in close vicinity of Axle Road Block.

Only one activating device either remote control or push button must be used at one time.

Only one person must operate the Axle Road Block at any given time.

Control panel is connected to 220 volts AC mains. High voltage components are exposed whenever the case is opened. Only trained person should carry out installation and maintenance.

Moving parts inside Mechanism box can cause serious injury. Only trained technicians should repair or replace the inside equipment.

The manufacturer is not responsible for any accidental damage for what ever the reason.

Warranty

HOM Automation provides a warranty of twelve months on all its products against all manufacturing defects and faulty workmanship from date of commissioning. However, any accidental damage is excluded from the warranty.

## **GENERAL MAINTAINANCE AND TROUBLE SHOOTING GUIDE:**

1. In case the remote is not giving proper signal (within normal range)
  - Battery could have become weak. Replace it with type 23A, 12V(preferably alkaline) battery. Make sure the battery is firmly and correctly in place. Battery life is six months with normal use.
  
2. In case the controller is working and system is not responding
  - Check if the motor is receiving power from the control card.
  - Check and clean the connector thimbles using fine sand paper.  
If the motor is receiving power but is still not rotating then there is possibility that motor is being jammed by some foreign object or loose pin or loose foundation. Lastly motor can be suspected to have burned out. If all is OK. Replace the electronic PCB.
  
3. If the power supply from the controller is not continuous or hangs up (cuts after 1 sec.)
  - Turn Power switch Off & On. This will reboot the controller.
  - One possible cause for electronics getting jammed is giving signals to open and close barriers in quick succession (before the motor stops). If barrier repeatedly misses signal, try to give 8-10 seconds interval between two signals.
  
4. If the Axle Road Block is not moving up fully (60 degrees) or coming down fully to horizontal position:
  - Check to see if the input voltage is 220 Volts. If the voltage fluctuates consider installing CVT.
  - If voltage is stable, check and clean connector / thimbles of AC motor.
  - Also observe if a friction is developed in moving parts.
  - If all above points are OK. Increase the total timer or high speed as follows:
  - To increase or decrease HIGH speed, rotate the oil controller valve clockwise or anti-clock wise provided in the mechanism box.

4A. To adjust duration (time duration power is supplied to motor)

To set the cycle time set dipswitches (Cycle Time) on Control Panel to OFF position.

If the cycle time is to be increased the dipswitches (cycle time) shall be turned to the OFF Position.

5. Adjusting operating time:

Operating time of Axle Road Block can be varied with the help of dip switches. To increase the operating time set the dip switch to up position and to decrease set the dip switch to down one by one as you required.

#### **Basic Operational Guide:**

- Push button is piano type. To give a signal it is to be pressed only for one second. Remote control and smart / proximity are to be used in the same way.
- Avoid dropping or keeping remote control in the back pocket. It is not covered under warranty as it is provided free of cost.
- If the spikes are out a signal from any activating device will send the spike down, making the passage safe for vehicles.
- If the spikes are under the surface a signal from any activating device will bring them out thus ready to Stop the vehicles, should a vehicle tries to go past them.
- If an auto-close mode inside control panel is switched on the spikes will come out automatically after a pre-set time (05,10 to15 sec).

TOP ELEVATION VIEW

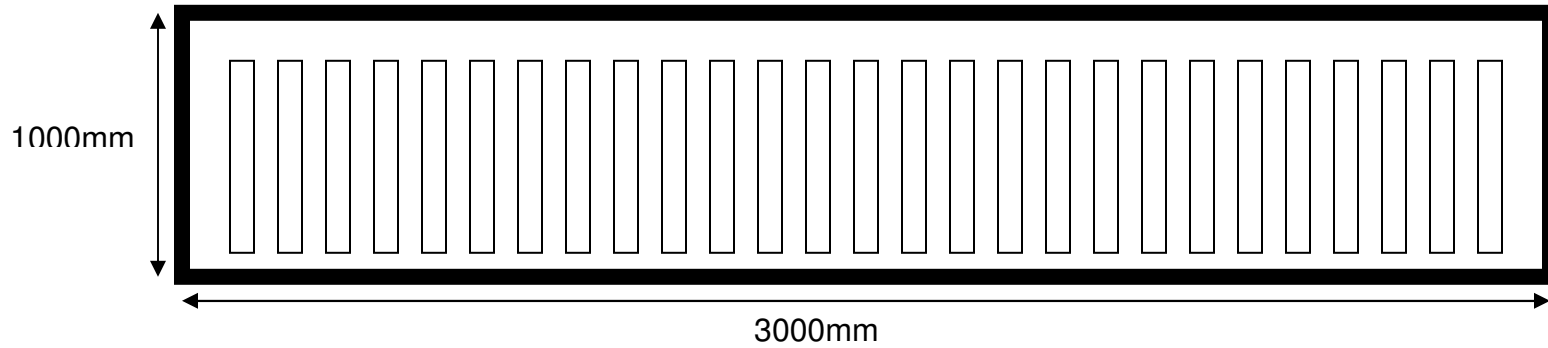

FRONT ELEVATION VIEW

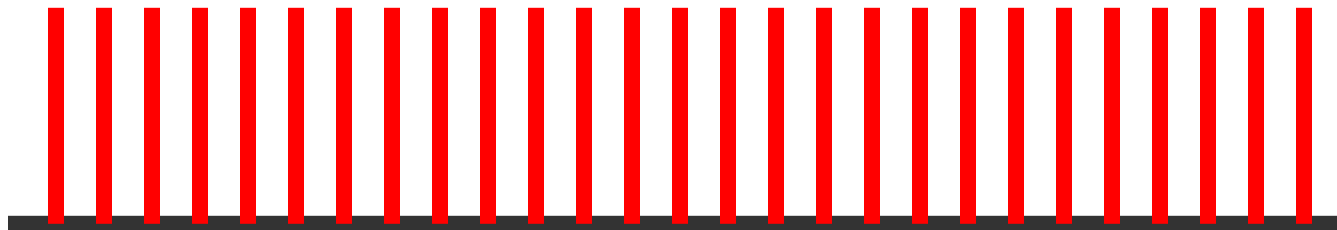

SIDE ELEVATION

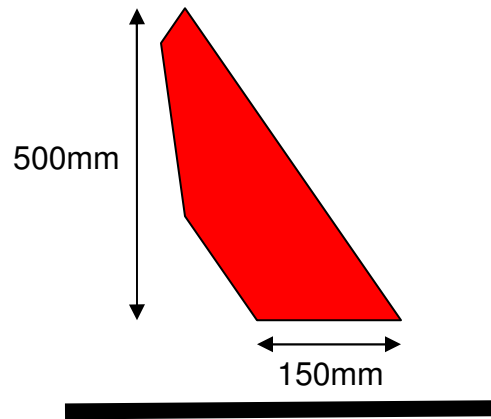

**Technical Support :**

HOM Automation Pvt. Ltd. Ph. 011-26820662, 011-26322356.

E-mail: [homautomation@vsnl.com](mailto:homautomation@vsnl.com),

[hom\\_automation@rediffmail.com](mailto:hom_automation@rediffmail.com)

Note: "HOM continuous development programme may bring specification changes without prior notice".